



ISUZU
ISUZU MOTORS INTERNATIONAL
OPERATIONS (THAILAND) CO., LTD.
1010 Shinawatra Tower III, 24th - 25th Floor,
Vibhavadi Rangsit Road, Chatuchak, Bangkok
10900, Thailand

ISUZU MOTORS INTERNATIONAL OPERATIONS (THAILAND) CO., LTD. reserves the right to change specifications and equipment without notice. Details of specifications and equipment mentioned or shown in this brochure are also subject to change to meet local conditions and government requirements. Features and specifications may vary in appearance and/or availability according to region. Accessories and equipment shown in this brochure have been used for illustrative purpose only. Some features may not be standard and are available at extra cost. Please inquire at your local ISUZU distributor or dealer for more complete details on available models and their specifications.



Printed in Thailand : September 2020

ISUZU
D-MAX

NEXT-GENERATION TOUGH

Welcome to the future of tough. From trademark durability to powerful performance, the all-new ISUZU D-MAX is more capable than ever before.

Featuring leading-edge safety, updated infotainment technology and all-day comfort, it's the result of a century of ISUZU's experience creating the world's finest commercial vehicles.

Redesigned from the ground up, the next-generation D-MAX is always ready and willing. With its wide stance and muscular design, it's as stylish as it is strong. New Bi-LED headlamps light the way, while sporty alloys and improved aerodynamics offer practicality and purpose. Whether off-road or on, at work or at play, the D-MAX redefines reliability – today, and every day after.

The all-new ISUZU D-MAX. Beyond pickup truck.



A Bi-LED headlamps with integrated daytime running lights:
Illuminate further and wider for maximum visibility.

B Integrated Rear bumper: The two-step bumper offers protection and a step to access payload cargo, with a new, one-piece design and more dynamic appearance.

C Tail lamps: Newly designed rear combination lamps with double LED lights provide improved visibility and safety.



THE POWER TO PERFORM



Having built more than 27 million engines internationally, ISUZU is the world leader in diesel engineering - and it shows. Combining responsive low-down torque with the power to get things done, the all-new D-MAX inspires confidence on every journey.

Both rugged and refined, its legendarily reliable engine is built to work. It delivers uncompromising performance while meeting the latest emissions standards - even as it improves on efficiency and economy. With boosted turbocharger response, precise fuel injection control and low engine noise, the all-new D-MAX is more accomplished than ever.

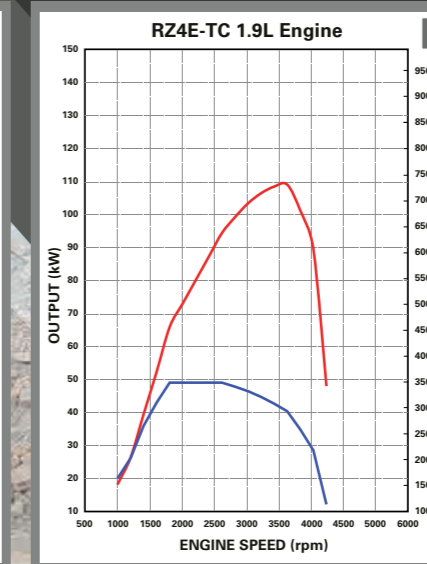
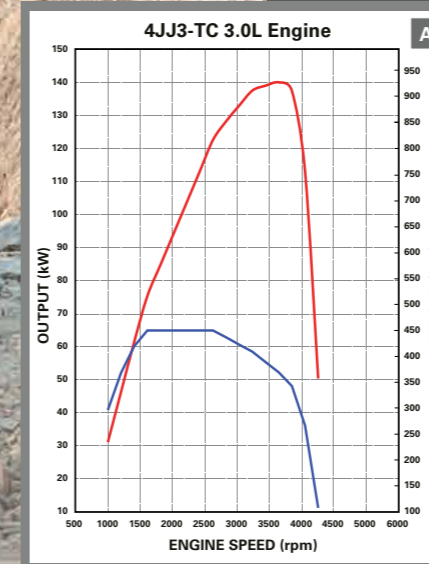

A ISUZU 3.0L Diesel Engine Performance:
Max.Power 140kW (190ps) / Max.Torque 450 N.m

B ISUZU 1.9L Diesel Engine Performance:
Max.Power 110kW (150ps) / Max.Torque 350 N.m

C Engine: Robust and refined reinforcing ISUZU's reputation for diesel durability.

D Electric Control VGS Turbocharger: Reduced lag, more power.

E Combustion chamber: Optimized combustion chamber minimises emissions while boosting economy.



Outstanding reliability is part of ISUZU's DNA of truck. The all-new D-MAX continues a tradition of toughness that began with the ISUZU's first ever pickup in 1963. Higher, wider and stronger than ever, the new model underwent the equivalent of over four million kilometres of testing during research and development, both on-road and off. It emerged as the toughest pickup in ISUZU's history.

The new D-MAX's lightweight body belies improvements in occupant protection, noise and vibration, as well as in overall stability. It is engineered for easy maintenance, with rock-solid rust protection and multiple maintenance-free components.

With its extended service life, the D-MAX is a rugged individual, built to keep going. Because life is too short for excuses.

GO HARD. GO HOME. REPEAT.

A Double scissors idler gear*: Reduced gear noise and vibration.

B Timing Chain: With auto tensioner minimises wear.

C Melt-in liner: The D-MAX's advanced anti-friction induction hardening process greatly strengthening the cylinders.



*for 4JJ3-TC engine

GET THE JOB DONE



The all-new D-MAX meets every challenge. New suspension minimises body roll while maintaining payload, as well as improving ride comfort. A choice of manual or automatic - each in six-speed - puts you in complete control, whatever your preference.

With outstanding performance and durability, the D-MAX comes alive off-road. A range of under-body armour provides maximum protection from rocks, knocks and hidden scrapes, while wading depth is increased to 800mm. In tight spaces, a turning circle of just 12.5 metres makes it easy to steer around obstacles - or, once you are finished, to turn around and do it all again.

Wherever you are planning to go, your D-MAX is up for the task.

- A 4x4 angles:** Improved approach, departure and ramp-over angles for even greater off-road capability.
- B Under body protection:** Meets the challenge of the toughest terrain.
- C Rear cargo:** Spacious and practical, with wide, flat loading area.
- D Chassis:** Bigger and stronger, with greater torsional and longitudinal rigidity for improved handling, stability and durability.

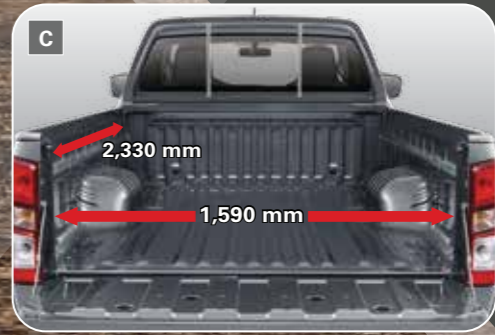
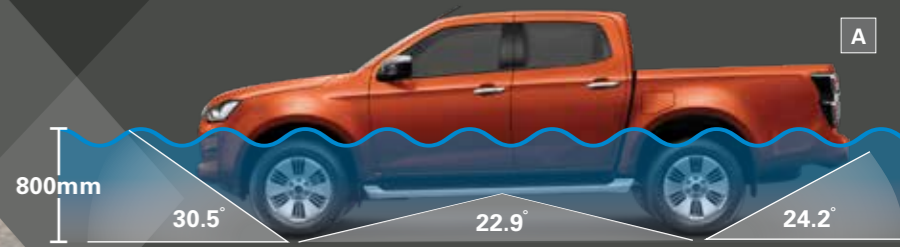

*Regular cab

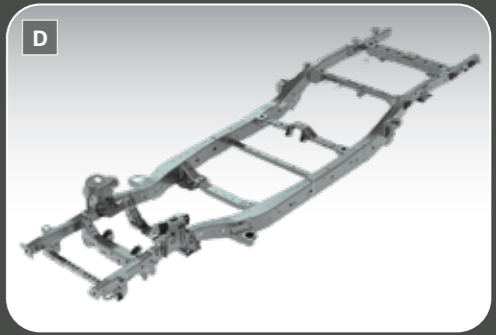

YOUR HOME ON THE ROAD



Comfortable, easy to use and flexible, the D-MAX is more than just a pickup. It is your mobile office, your place to relax, and your passport to adventure.

ISUZU's universal design concept means that every feature is tailored to you. There is a well-appointed, spacious cabin, easy entry and exit, and impressive new interior design. A redesigned seat - electrically adjustable in eight different ways - lets you find the perfect driving position, along with tilt and telescopic adjustment of the steering wheel. Every seat has softer cushioning and firmer lateral support, while abundant storage options fall easily to hand, whether you are in front or back. Dual-zone climate controlled air conditioning, reduced cabin noise and minimal vibration make every journey a pleasure.

Whether you are with the family or on the job, the all-new D-MAX is one step ahead. This is the next evolution of ISUZU.

A Steering wheel: Smaller and sportier, with tilt and telescopic adjustment for the perfect driving position.

B Rear console with air-conditioning vent: Comfort and the convenience of a USB port for back-seat passengers.

C Storage: Every door has space for a 1.5L bottle.

D Dual-zone climate control: The driver and front-seat passenger can set individual temperatures to suit their personal preference.

E Leather-appointed seat with lumbar support: Ergonomically designed, with anti-vibration elastic comfort foam and an eight-way adjustable driver's position.



TOTAL CONTROL

The all-new D-MAX features an array of intuitive technology built to make your life easier.

A large, customisable touchscreen offers Apple CarPlay™ and Android Auto™, as well as voice recognition and up to eight speakers. A large 4.2" TFT display provides the driver with all important information - right in the centre of the instrument cluster. And the D-MAX keeps you charged and ready on the move, with multiple USB ports in the front and back seats.

If that is not all, there is also an array of technology designed to bring you closer to your car. Features include Remote Engine Start, allowing you to turn on the air-conditioning before you get to the car, Walk Away Lock, which secures your doors automatically when you are more than three metres away, and Follow Me Home lighting, which lights the area around your D-MAX when you exit after dark.

Welcome to the most advanced D-MAX ever. It's designed for you.

A Large 4.2" TFT Multi-Information Display: Shows various vehicle functions according to the driver's preference.

B Infotainment with Apple CarPlay™ and Android Auto™: Replicates the functions of your smartphone while driving, including voice recognition.

C Multiple USB ports: Easy access for both front and rear occupants.



YOU'RE IN SAFE HANDS



There is nothing more important than the wellbeing of you and your family. That is why the all-new D-MAX is built for maximum peace of mind. It includes a range of safety features that operate automatically and independently, working to resolve dangerous situations - usually before the driver is even aware they are in trouble. Additional systems, such as Hill Start Assist (HSA) and Hill Descent Control (HDC), provide extra confidence in difficult circumstances, whether on- or off-road.

The body of the new D-MAX is strengthened to better protect its occupants from external impact from any angle. Larger brakes front and rear increase stopping power - the better to prevent accidents in the first place - while the seats are designed to absorb impact in an emergency. And should any of the D-MAX's airbags be deployed, the doors of the pickup unlock automatically.

As well as protecting you, the D-MAX is safer for those around you. Pedestrian Protection minimises harm to those outside the car in the event of a collision.

Because confidence is about more than just conquering the toughest terrain. It is about knowing you are in the safest of hands - on every journey.

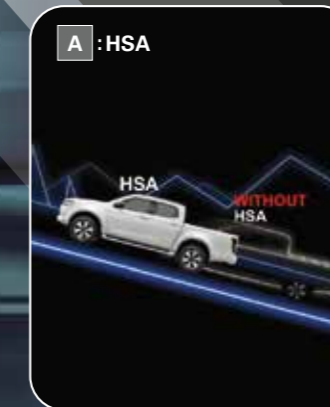

A HSA and HDC: Hills Start Assist and Hill Descent Control ensure maximum confidence in uneven terrain.



B Reinforced cabin: Fabricated with High Tensile Steel for outstanding strength and rigidity to create a passenger safety cell.

C Bigger brakes: Significantly reduced brake noise, significantly improved service life and brake feel.